

ULTRAVAC® 225

SINGLE CHAMBER VACUUM PACKAGING MACHINE

The Koch space-saving Ultravac® 225

In less than 3.25 square feet (19" x 24.6") of counter space you can begin vacuum packaging. Vacuum package a wide range of small to large size products. Vacuum chamber size: 7.25" high x 16.75" x 19.56" long. Up to 3 cycles per minute.

- Quick-change, 16" seal bar.
- Koch Pozi-Pressure™ radius surface sealing element seals through contamination, folds and wrinkles.
- Compact tabletop model saves valuable counter space.
- Simple operation and easy-to-use controls.
- Ideal for small to medium processors, restaurants and supermarkets.
- Patented lid hinge system, increases opening angle for easier product loading.



PATENT PENDING



NEW

Optional Features:

- Gas Flush
- Single Seal with Cut Off
- Double Seam Sealing
- Digital Control Panel
- Acrylic Clear Lid

Never Offered Before
for the Ultravac® 225

KOCH

EQUIPMENT

Koch Equipment LLC
1414 West 29th Street
Kansas City, MO 64108-3604 USA

800-777-5624

Telephone: (816) 753-2150

Fax: (816) 753-4976

E-mail: info@kochequipment.com

Internet: kochequipment.com

© Copyright 2006 Koch Equipment LLC

ULTRAVAC® 225



SINGLE CHAMBER VACUUM PACKAGING MACHINE

Injection molded from high-tech, engineered composite.

Space-age, engineered-resin composite materials in the Ultravac® 225's chamber lid, basin and chassis are amazingly flexible yet virtually indestructible. This composite was developed with input from a Technology Transfer Program between Koch and the U.S. Department of Energy. Both lid and basin are smooth and seamless with large radius corners for easy, thorough cleaning and inspection.

Quick-change, 16" seal bar.

Features Koch's Pozi-Pressure™ radius-surface sealing element for sealing through contaminants, folds and wrinkles.

Large capacity chamber.

The Ultravac® 225 vacuum chamber size: 7.25" high x 16.75" wide x 19.56" long.

Standard Features

- Busch® 021 vacuum pump
- 20 gauge stainless steel construction
- Koch patented lid hinge system
- Heavy duty transformer (200VA)
- High density polyethylene filler boards
- Electrical connection 120V, 1 phase, or 220V, 1 phase available
- NEMA 4 washdown controls

Koch Ultravac® 225 Single Chamber Vacuum Packaging Machine

FEATURES	
A Length	19.25"
B Width	25"
C Maximum Height	31.75"
D Working Height	14.375"
Seal Bar Length	16"
E Chamber Length	19.56"
F Chamber Width	16.75"
G Chamber Height	7.25"
H Between Seal Bar and Back of Chamber	17.25"
Vacuum Pump	0.95kW (1.25hp)
Net Weight	121 lbs.
Electrical Connection	120V, 60Hz, 13amp
(1 phase)	220V, 50Hz, 6.5amp
Capacity	20-30 seconds per cycle

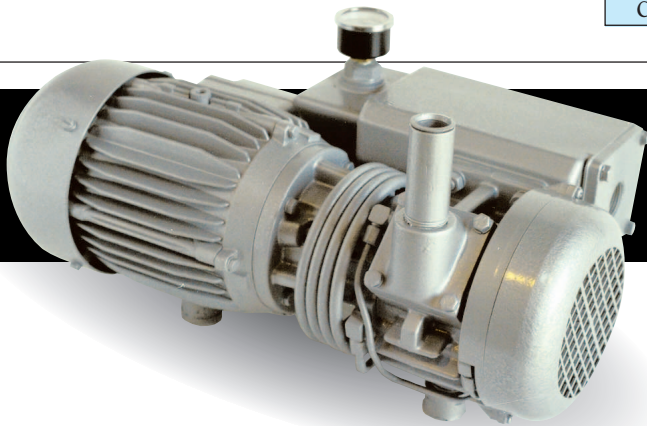

The heavy duty, 1.25hp Busch® 021 vacuum pump powers the Ultravac® 225 for years of dependable service

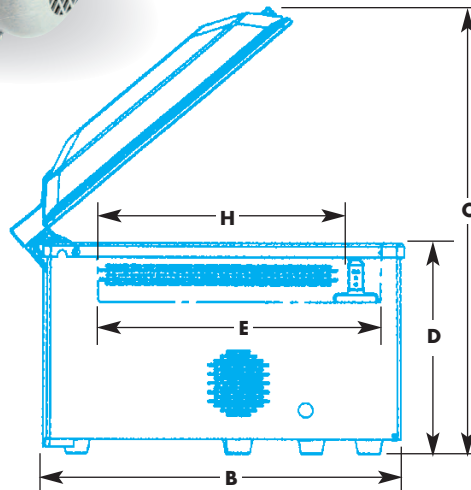
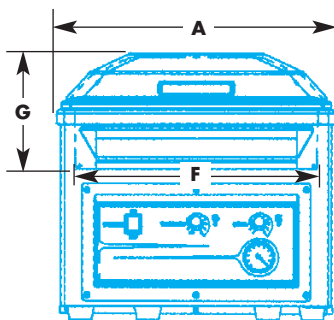

ETL Listed, conforms to:
UL-73, CSA-C22.2 No. 68-92, NSF-2

KOCH
EQUIPMENT